

Horizontal Profiled Metal on Cavity Head

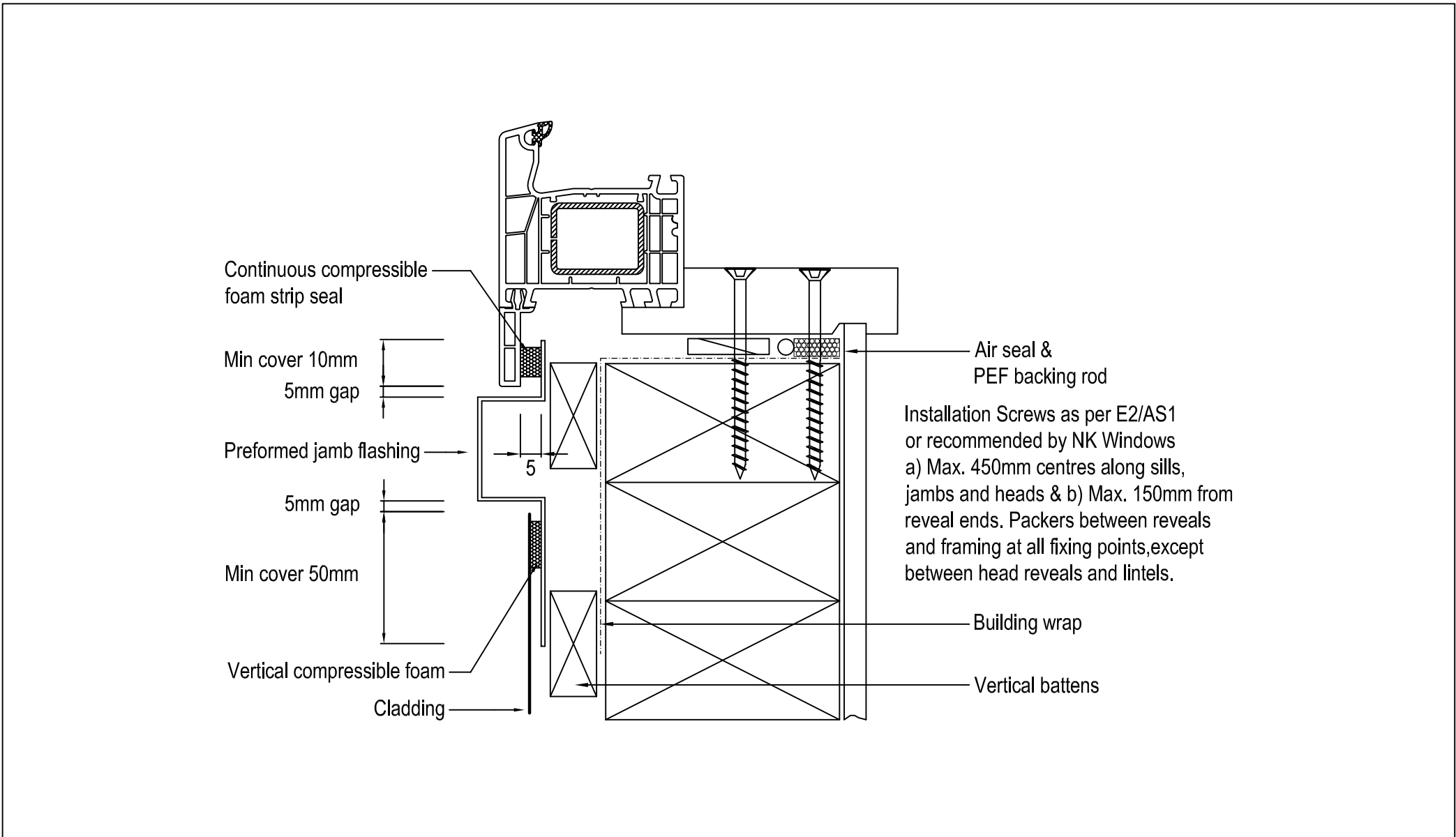

Horizontal Profiled Metal on Cavity Jamb

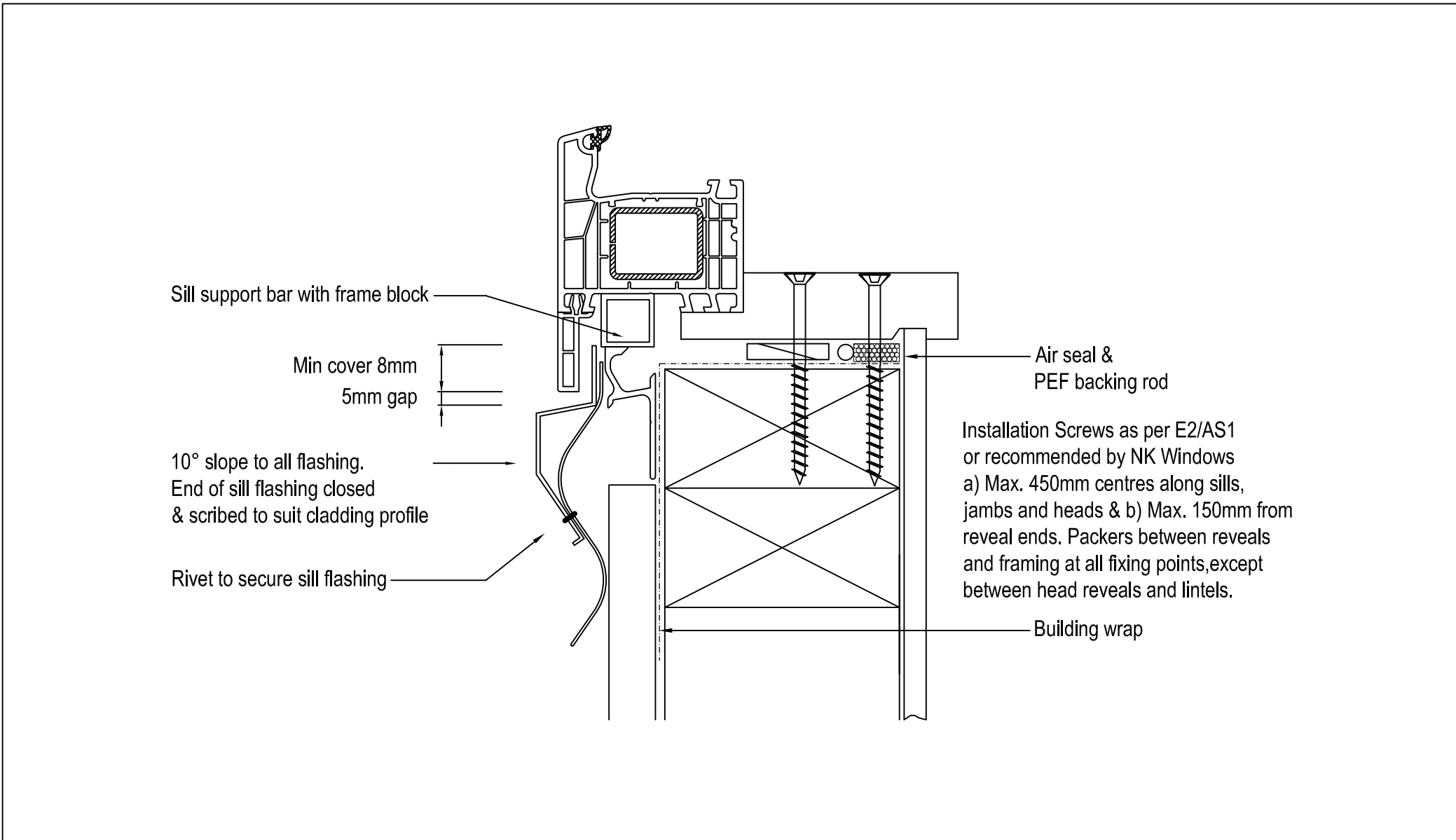

Horizontal Profiled Metal on Cavity Sill